

EP-M300

High Productivity Metal AM Machine
Metal Powder Bed Fusion

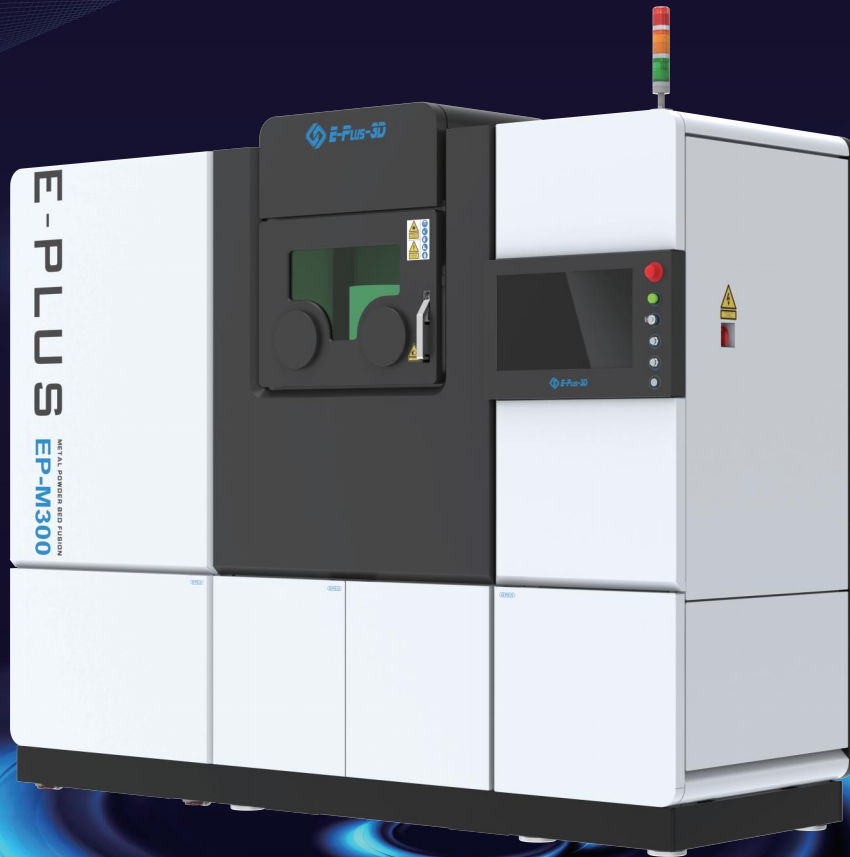

EP-M300

Eplus3D introduces EP-M300 to the successful line of MPBF™ metal AM solutions. The new EP-M300 is a marvelous metal printer that makes the production of reliable and high quality large metallic parts viable on industrial scale without requiring any tools.

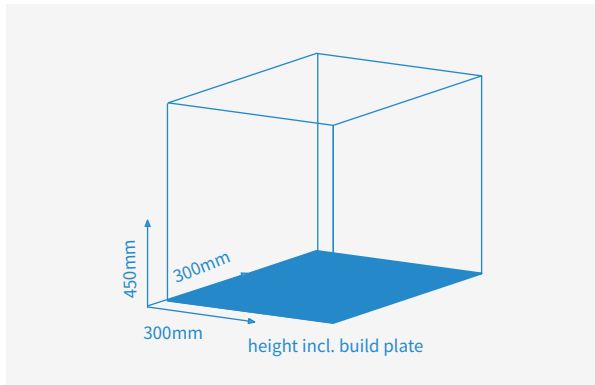

« OPTIMIZED MECHANICAL DESIGN

- Big building chamber, single or dual laser optional.
- User friendly, dual filter systems, high security.
- Various of performance recoating lips available.

» OPEN SYSTEM

- Open parameters for editing laser power, scan speed, scan direction, up and down facing surfaces etc.
- Open system ensures free choice among a wide range of metal powders in the market.
- Various material parameter packages available.
- Process software supports SLC and CLI formats.

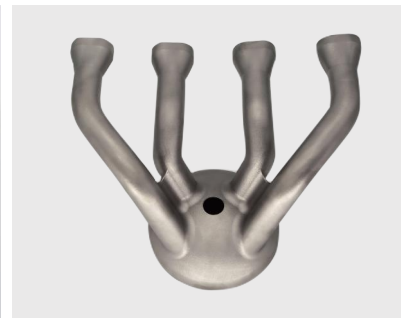

» HIGH QUALITY

- High density and less deviation of the printed parts.
- The optimized gas flow design ensures efficient removal of smoke and splatter as well as achievement of uniform and consistent full size printing.
- Dynamic software with ability to divide the model into different sections like upper and lower surfaces, core areas and small areas etc.

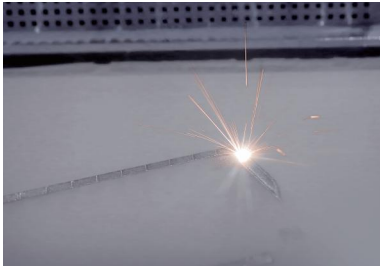

« RELIABLE & HIGH SAFETY

- Excellent core optic components from world-class suppliers and mature process control parameter algorithm provides highest part quality.
- High quality uniform part printing due to excellent control over building environment and components.
- Double locking from mechanical lock to improve safety.
- Alarming when the access door is open abnormally, to ensure the safety of use.
- Two-glove structure of the access door makes it possible to operate without opening the door.

» HIGH EFFICIENCY

- Build volume (X x Y x Z) is up to 300 x 300 x 450 mm (height incl. build plate).
- Printing with increased layer thickness can be realized to improve production capacity.
- With in-house developed processing software (EPHatch), optimized scanning strategies can be achieved yielding reduced print duration.



« COST-EFFECTIVE & EASY OPERATION

- Blowback enabled coarse and fine gas-filtration system with 1500 hours.
- Highly user friendly software interface and one-click printing technology makes printing super simplified.
- Reduced gas consumption during printing ≤ 6 L/min helps reducing operation cost.



EP-M300

PARAMETER

Machine Model	EP-M300
Build Volume (X x Y x Z) (height incl. build plate)	300 x 300 x 450 mm (11.81 x 11.81 x 17.72 in)
Optical System	Fiber Laser 500 W / 700 W (single or dual-laser optional)
Spot Size	70 - 120 μ m
Max Scan Speed	8 m/s
Layer Thickness	20 - 120 μ m
Theoretical Printspeed	Up to 95 cm ³ /h
Material	Titanium Alloy, Aluminum Alloy, Nickel Alloy, Maraging Steel, Stainless Steel, Cobalt Chrome, Copper Alloy, etc.
Power Supply	380 V, 50 / 60 Hz, 5 / 8 kW
Gas Supply	Ar / N ₂
Oxygen Content	≤100 ppm
Dimension (W x D x H)	2990 x 1320 x 2590 mm
Weight	2900 kg
Software	EPControl, EP Hatch
Input Data Format	STL or other Convertible File

Notice: Eplus3D reserves the right to explain any alteration of the specifications and pictures.